

MOTORCYCLE UNIT PLUS 1

BASE INSTRUCTIONS

Flat and firm base. Recommended: concrete, tarmac or paving flags.
 Min. distance from walls/ shrubbery: 1000mm.
 Min. base size (WxDxH) 4824mm x 1730mm x 50mm.

LEVELING THE UNIT

Correctly level the constructed unit using the shims (ZCOMPPLAS) provided prior to fixing the unit to the ground. Slide the packing pieces under the corners of the unit base as required until an equal gap has been achieved around the door allowing for its smooth operation and alignment.

It is always recommended to anchor the unit to the ground. Drill through the four holes in each of the base of the unit using 6mm dia masonry drill to a depth of 70mm. Screw in the anchor fixings. (These have a self cutting thread). If not anchoring the unit, fit the self seal plugs BEFORE BUILDING to seal the fixing holes from underneath. **Please note product must be bolted down to comply with LPS1175.**

TOOLS REQUIRED

Power driver POSI-DRIV screwdriver, 6mm dia. masonry drill and a 10mm socket or spanner.



Warning: some panels may weigh over 20Kg
 Beware of manual handling

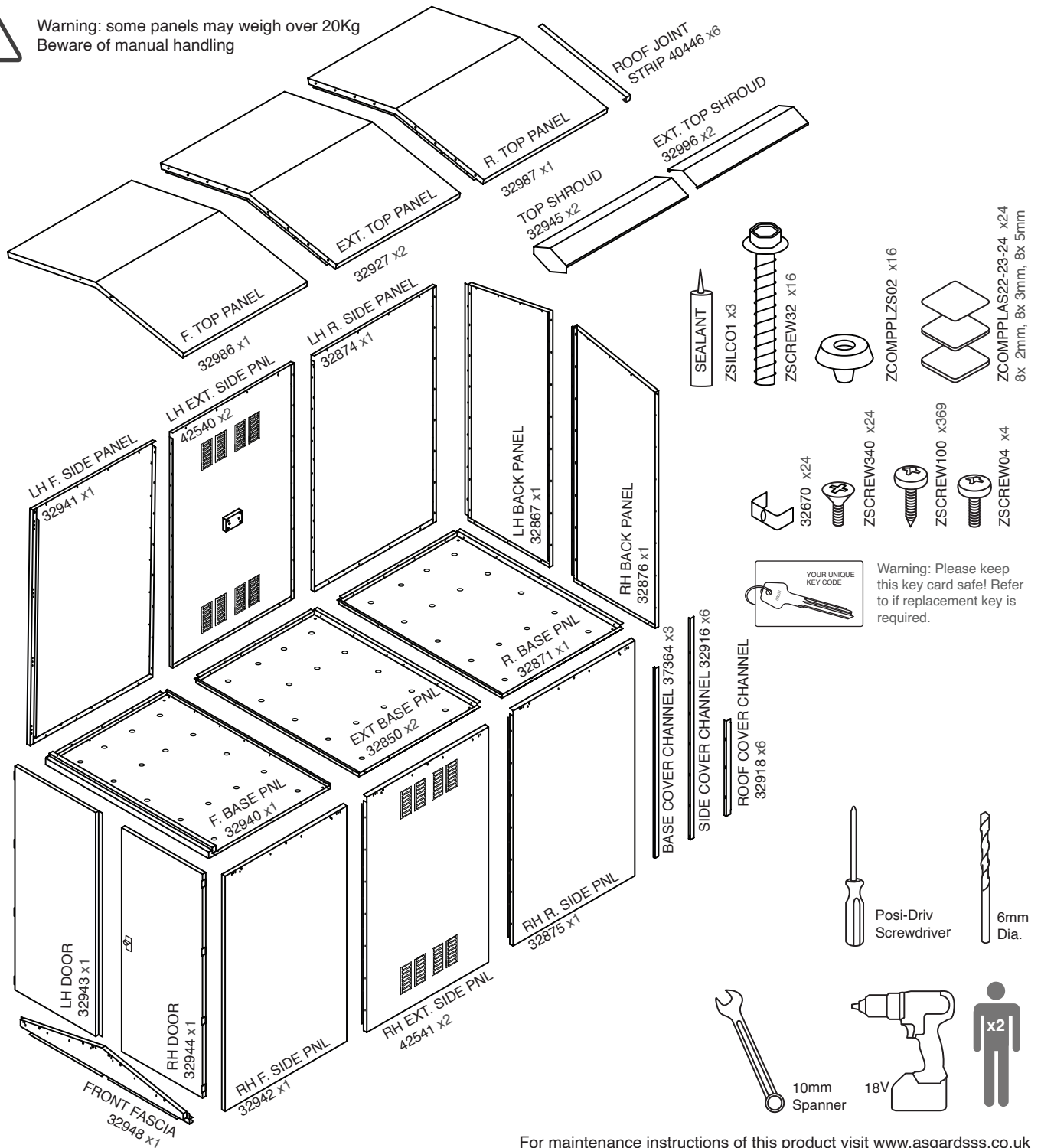

PLEASE NOTE ALL SCREWS ARE FIXED FROM THE INSIDE

1

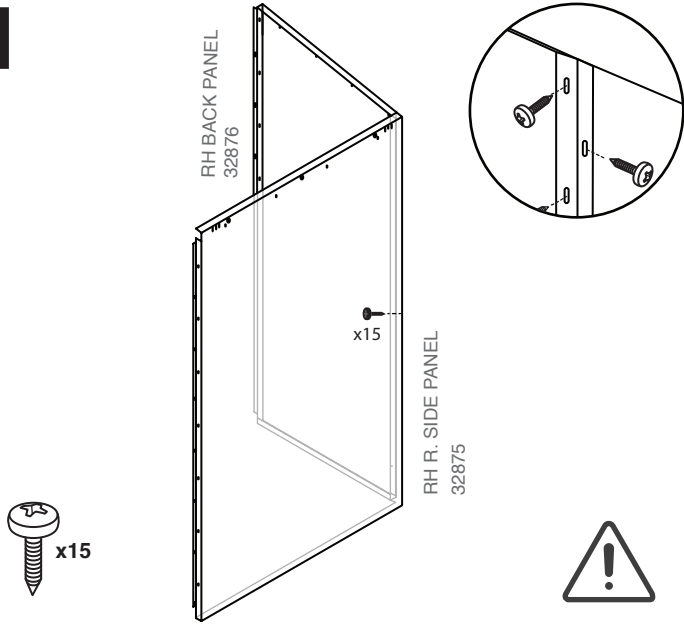

2

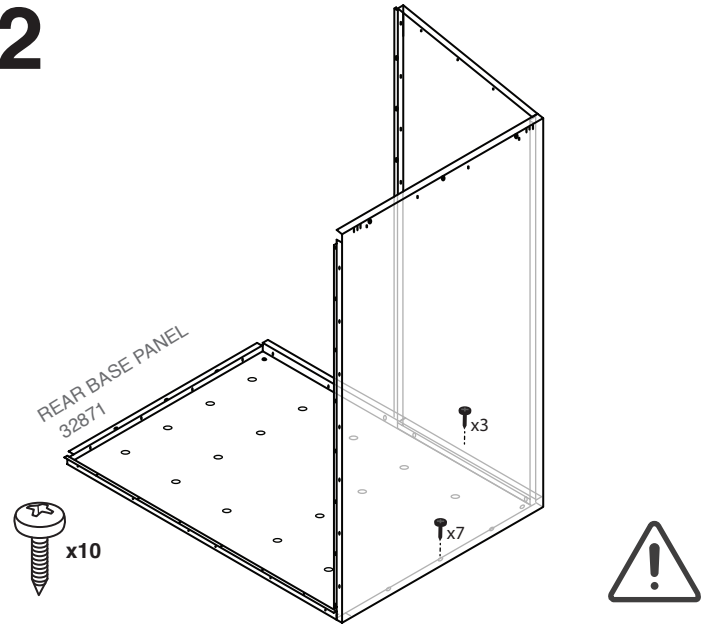

3

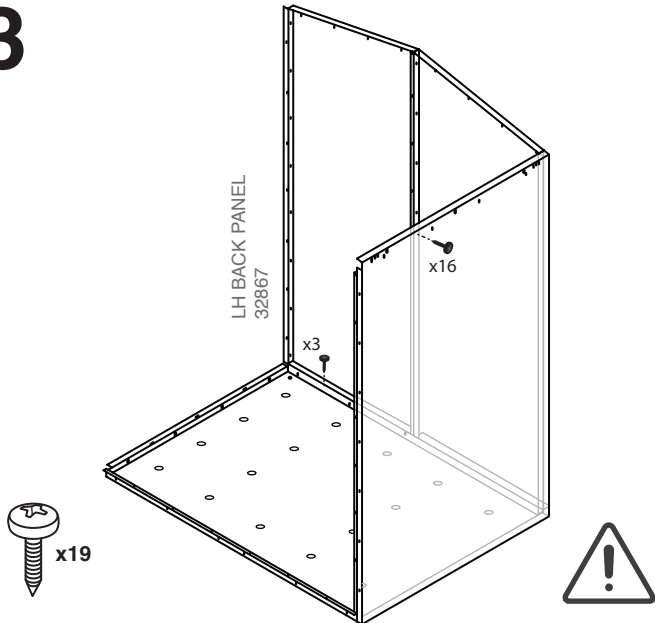

4

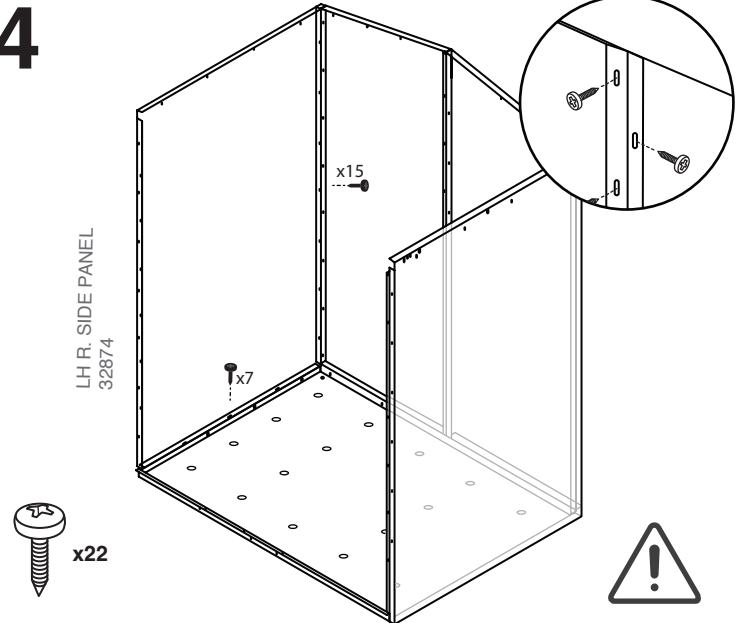

5

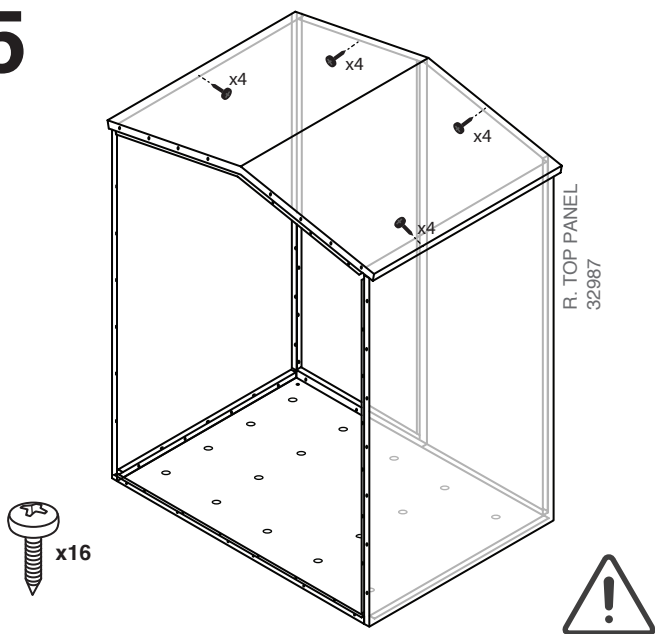

6

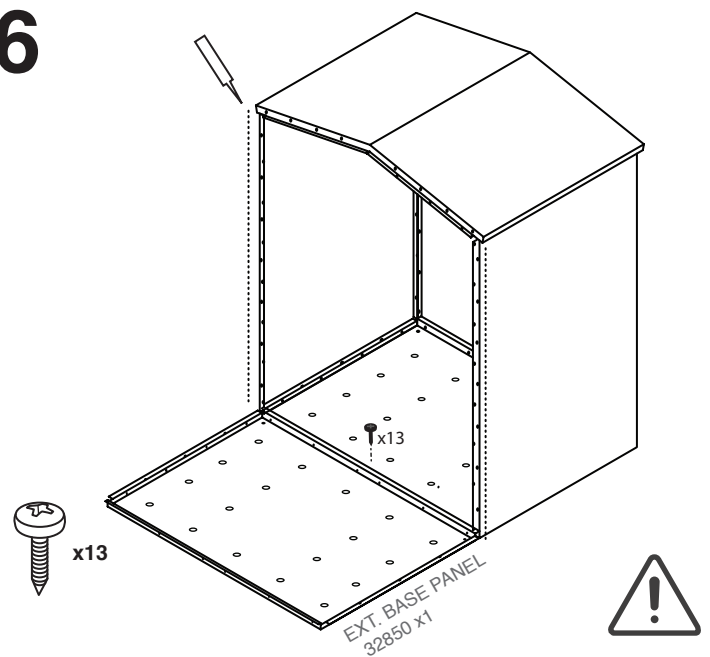

7

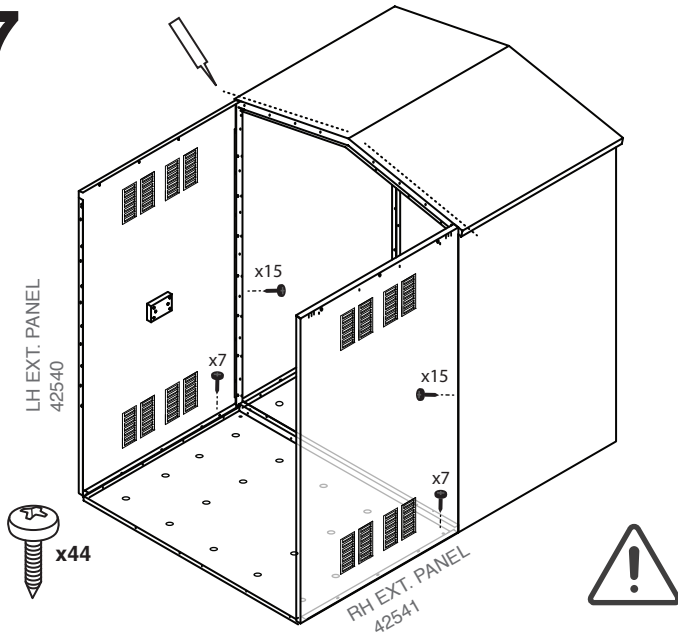

8

REPEAT 6-8 TWICE

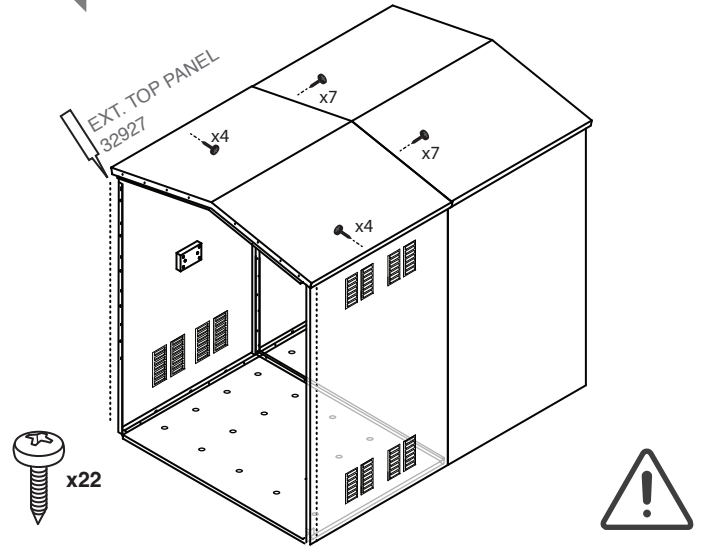

9!

IF YOU HAVE AN OPTIONAL RAMP,
PLACE UNDERNEATH FRONT
BASE PANEL AT THIS STAGE

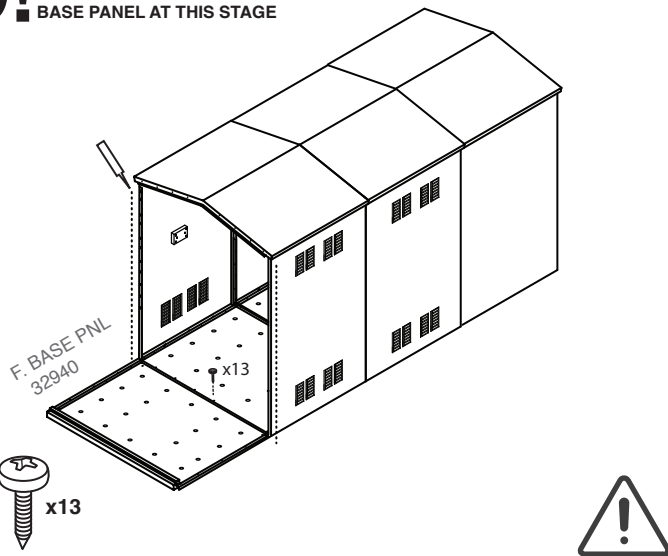

10

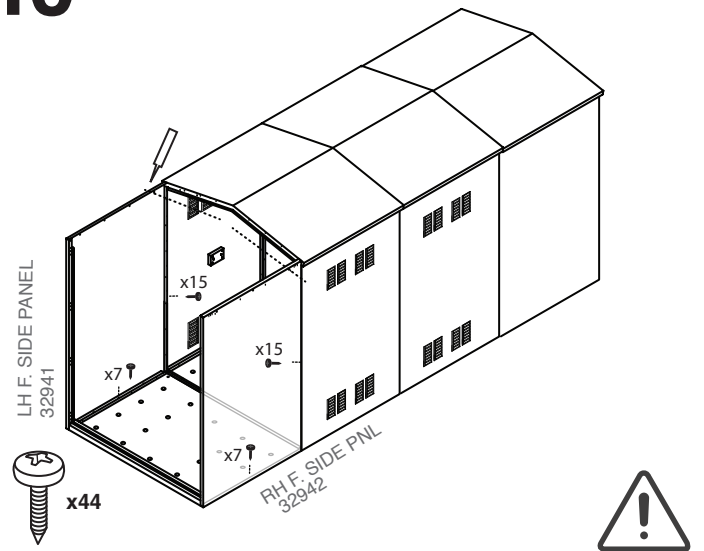

11

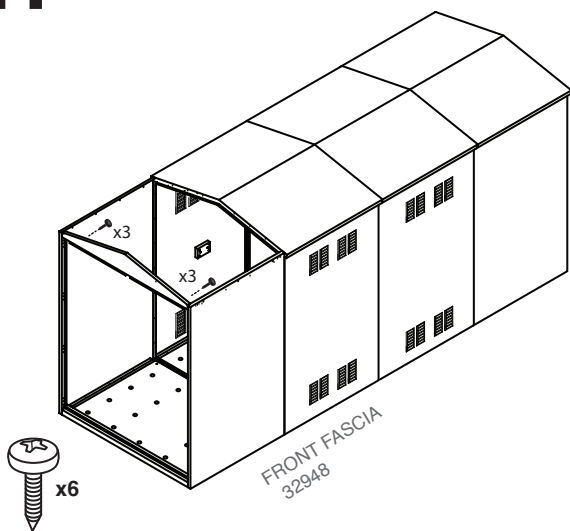

12

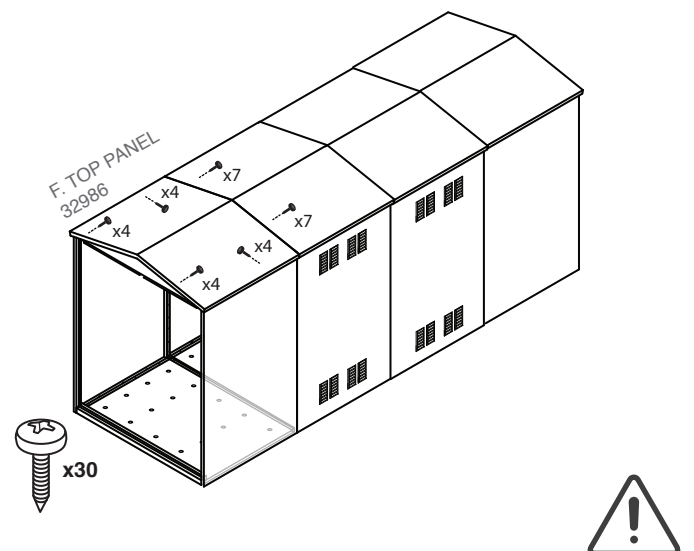

13

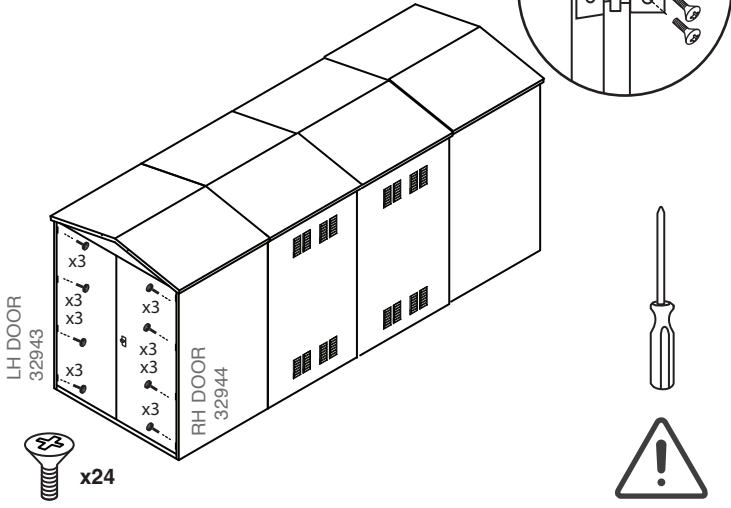

14! NO SCREWS REQUIRED TOP END OF STRIP TRAPPED UNDER TOP CAP

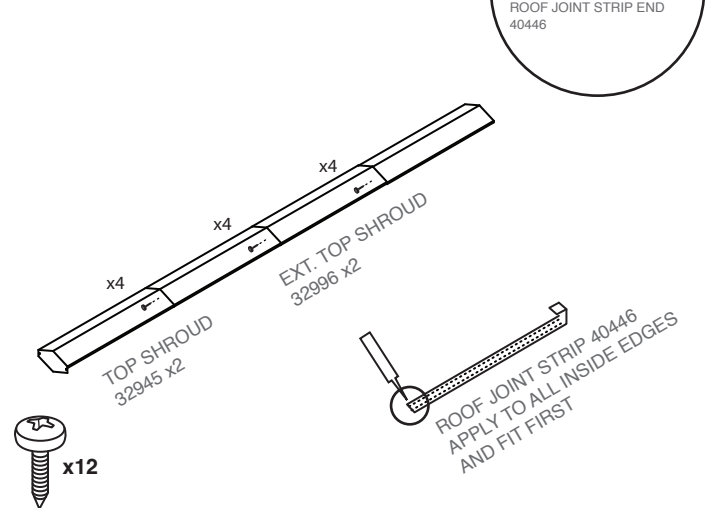

15

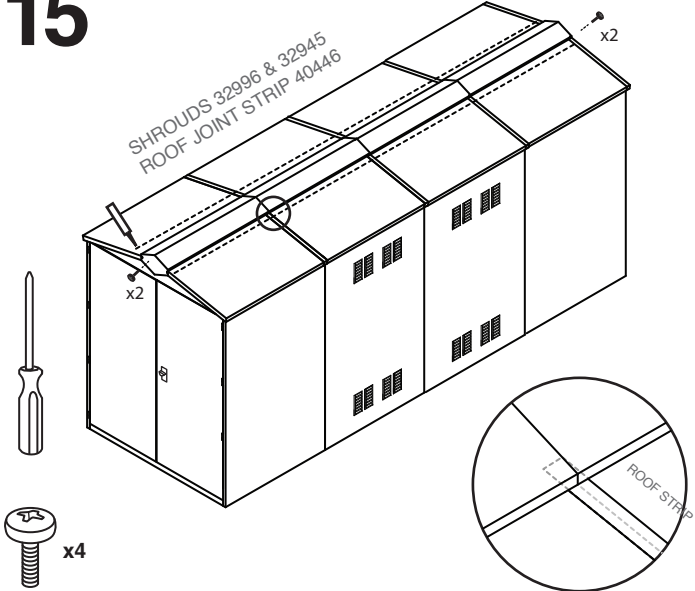

16

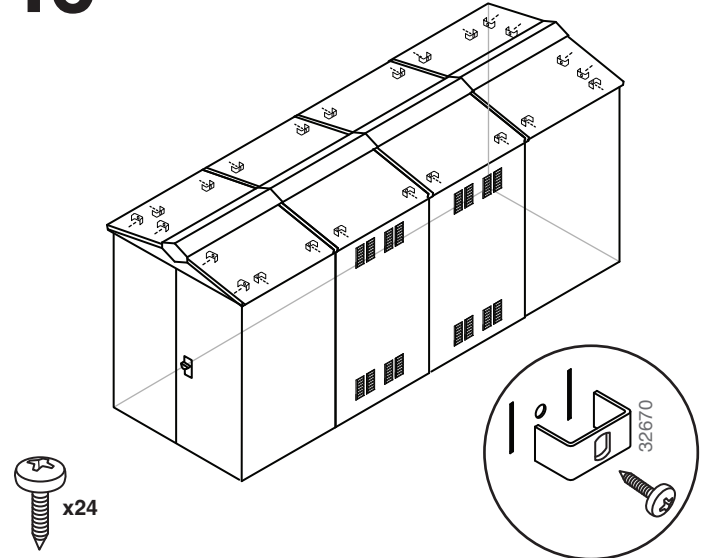

17! REMOVE SCREWS WHICH ALIGN WITH THE COVER CHANNELS. ALIGN AND PLACE SCREWS BACK

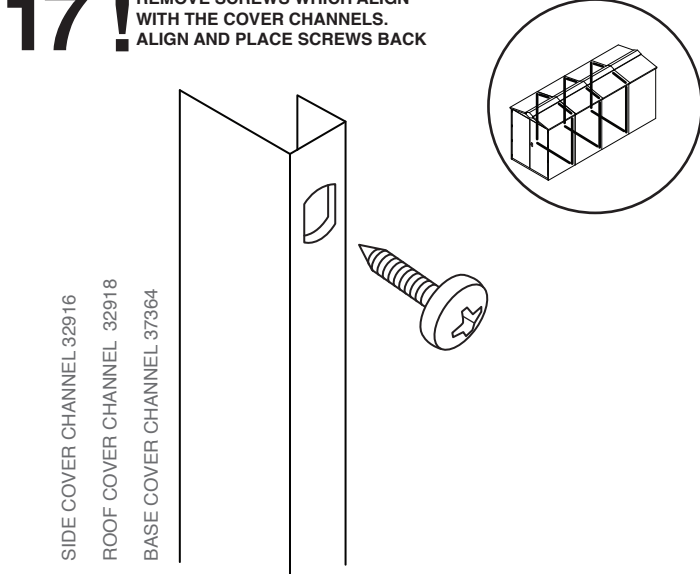

18! LEVEL SHED UNTIL DOORS ALIGN USING ZCOMPPLAS AS SUITABLE

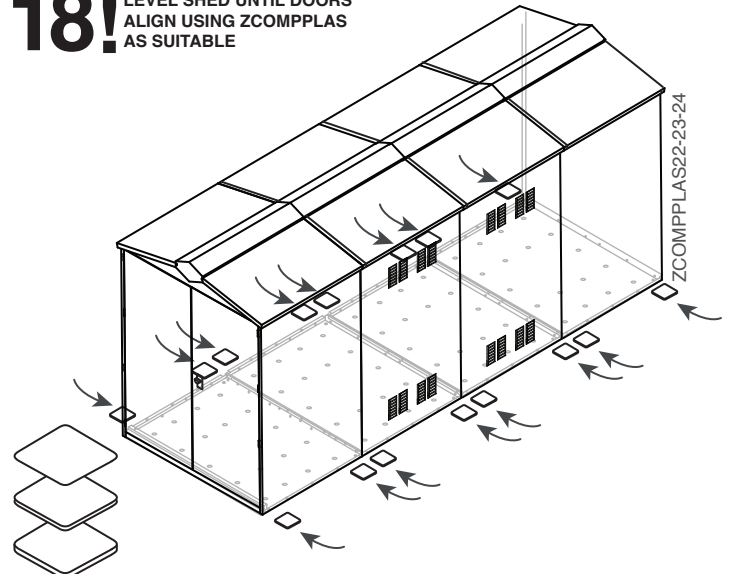

19

